

Fostex®

LOW LEAKAGE FLUX TYPE FULL RANGE
SPEAKER UNIT

FE107E

Features

- 'ES cone' paper made of banana plant's fiber
- Newly designed center cap
- Repulsion type magnetically shielded circuit
- Ferrite magnet

Specifications

&

Thiele/Small Parameters

Size	:	100 mm / 4 in
Voice Coil Diameter	:	20 mm / 0.8 in
Cast / Stamped	:	Stamped
Impedance	:	8 Ω
Reproduction Frequency Response	:	fs - 22 kHz
Sound Pressure Level	:	90 dB/W(m)
Rated Input	:	5 W
Music Power	:	15 W
Magnet Material	:	Ferrite
Magnet Weight	:	
(main)	:	101 g / 0.223 lb
(cancel)	:	59 g / 0.130 lb
Net Weight	:	550 g / 1.213 lb

a	:	40 mm
D	:	80 mm
Sd	:	0.00503 m ²
Zn	:	8 Ω
Fs	:	80 Hz
Re	:	7.60 Ω
Le	:	n/a mH
Qms	:	2.56
Qes	:	0.45
Qts	:	0.38
Mms	:	2.6 g
BL	:	4.7 Telsa/m
Vas	:	5.95 L
Xmax	:	0.35 mm
Eff/η0	:	0.35 %
Cms	:	0.00168 mm/N
EBP	:	178



Frequency Response / Impedance

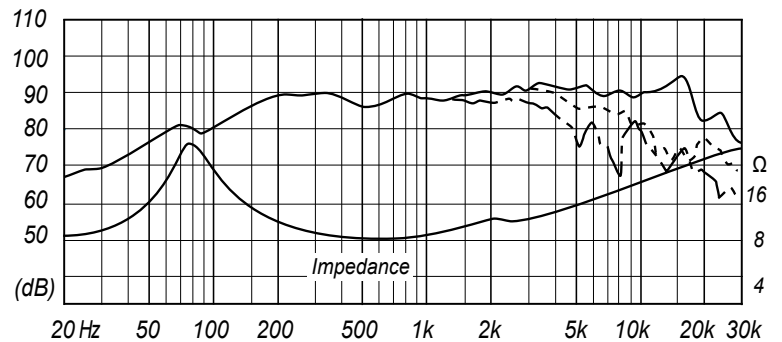

Dimensions & Mounting Information

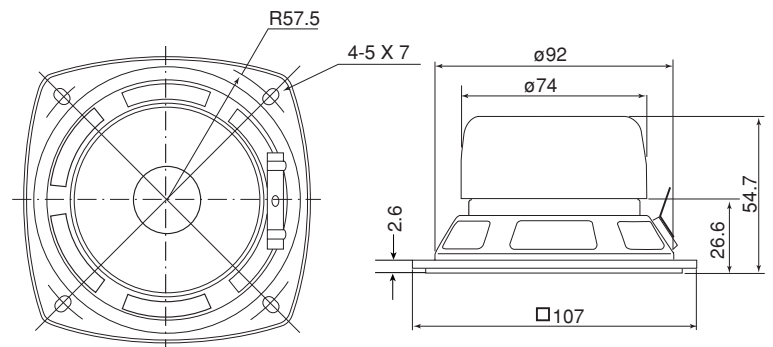

Overall Diameter	:	107 mm / 4.2 in
Baffle Hole Diameter	:	74 mm / 2.9 in
Depth	:	54.7 mm / 2.2 in

FE107E

Recommended Double Bass Reflex Type Enclosure

- This is an example of FE107E double bass reflex type enclosure suitable for audio/video systems or other shielded applications.

- Multiple bass reflex ports (ports) reproduce lower frequency.

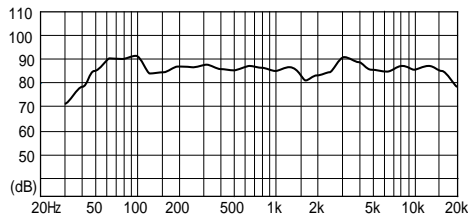

- Using a good Dolby Digital surround processor, movie theater quality sound stage can be achieved.

unit:mm / 15mm thick / fb1 = 110Hz (1st), fb2 = 55Hz (2nd)

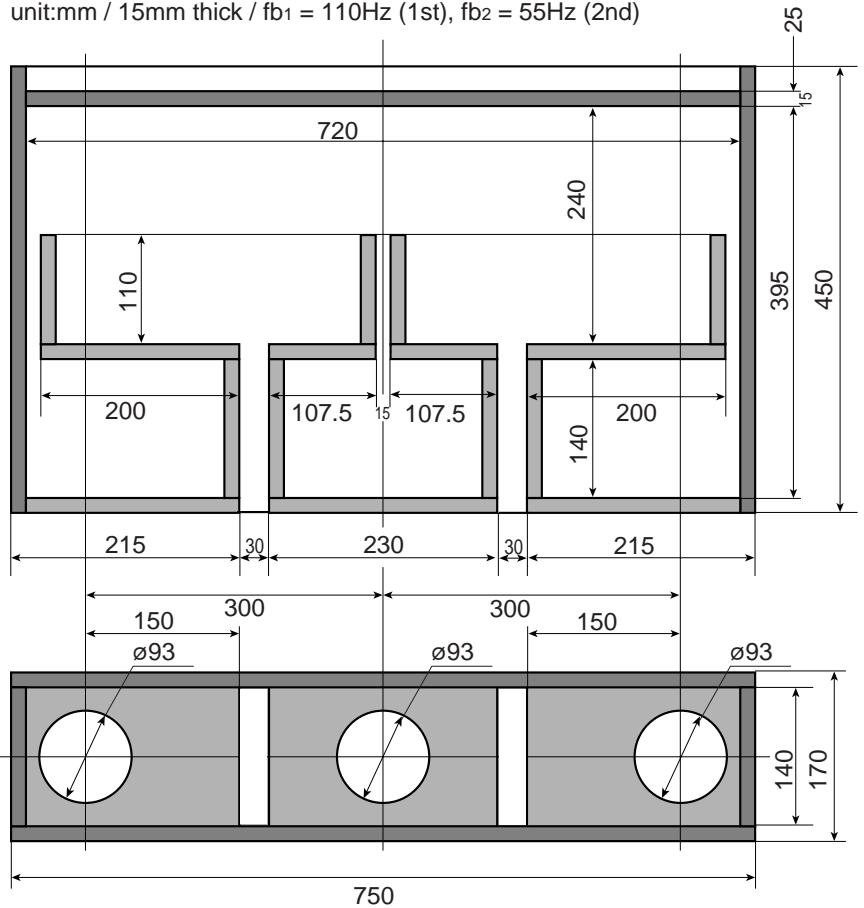

Recommended Standard Bass Reflex Type Enclosure

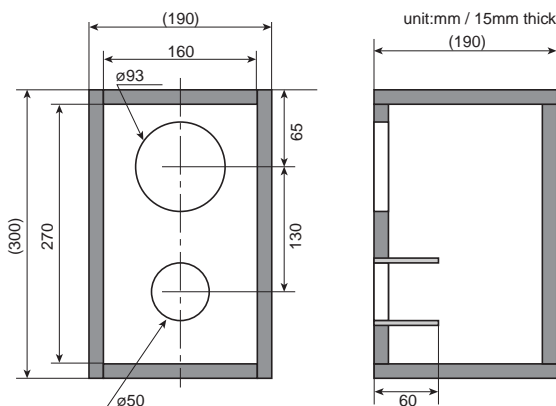

Example of FE107E standard bass reflex type enclosure. Internal volume is 6 liters tuned to approximately 95Hz (Fb).

